



Battery Management Innovation

Celltron[®] START+[™]

Electrical System Analyzer

*For testing 6- and 12-volt engine crank/
generator starting, automotive, and
marine batteries and 12- and 24-volt
charging systems.*



INSTRUCTION MANUAL

TABLE OF CONTENTS

TEST PREPARATION	3
OUT-OF-VEHICLE TESTING	3
IN-VEHICLE TESTING	3
CONNECTING THE ANALYZER	3
USING THE KEYPAD	4
SELECTING A TEST MODE	4
SELECTING A TEST OPTION	5
ENTERING BATTERY INFORMATION	5
TESTING THE BATTERY PACK	6
BATTERY PACK TEST RESULTS	7
TESTING INDIVIDUAL BATTERIES	7
INDIVIDUAL BATTERY TEST RESULTS	7
TEST CODE	8
TESTING THE STARTER SYSTEM	8
SELECTING A STARTER TYPE	8
STARTER SYSTEM TEST RESULTS	9
TESTING THE CHARGING SYSTEM	9
CHARGING SYSTEM TEST RESULTS	11
Charging System Decision	11
Charging System Problem	11
Load Voltage Measurement	11
Alternator Ripple Evaluation	11

MENU OPTIONS	12
VIEW RESULTS	12
PRINT RESULTS	12
VOLTMETER	13
SET ADDRESS	13
PERFORM TEST	13
ADDITIONAL FEATURES	14
SYSTEM SAVER	14
SURFACE CHARGE REMOVAL	14
TEMPERATURE COMPENSATION	14
BEFORE AND AFTER CHARGE TESTS	14
GLOW PLUG DETECTION	15
TROUBLESHOOTING	16
DISPLAY PROBLEMS	16
PRINTING PROBLEMS	17
Status LED	17
Solutions	17
REPLACING THE ANALYZER BATTERY	18
PATENTS, LIMITED WARRANTY, SERVICE	21

TEST PREPARATION



CAUTION: *Because of the possibility of personal injury, always use extreme caution when working with batteries. Follow all BCI (Battery Council International) safety recommendations.*

OUT-OF-VEHICLE TESTING

- Clean the battery terminals with a wire brush before testing.
- For Group 31 batteries, clip onto the lead pads or install and tighten the lead terminal adapters provided with the analyzer.

IMPORTANT: Do not connect battery clamps to the steel bolts on Group 31 batteries. Failure to properly install terminal adapters, or using dirt or worn terminal adapters, may result in false test results.

IN-VEHICLE TESTING

- The preferred test location is at the battery terminals where the battery back is connected to the vehicle. If CHECK BAT.PACK is the decision, disconnect the batteries and retest each battery ensuring the battery clamps make good contact with the lead portion of the battery terminals.
- At the start of the test, ***make sure all vehicle accessory loads are off and the ignition is in the OFF position.***

CONNECTING THE ANALYZER

1. Connect the red clamp to the positive (+) terminal.
2. Connect the black clamp to the negative (–) terminal.
3. For a proper connection, rock the clamps back and forth. Both sides of the clamp must be firmly connected before testing. If the message CHECK CONNECTION appears, clean the terminals and reconnect the clamps

USING THE KEYPAD

Press the **ARROW** buttons to scroll through menu choices.

Press the **ENTER** button to make selections.

Press the **BACK** button to move to the previous step.

Press the **MENU** button to make the following options available:

- PRINT RESULT
- VIEW RESULT
- VOLTMETER
- PERFORM TEST
- ENTER NAME AND ADDRESS

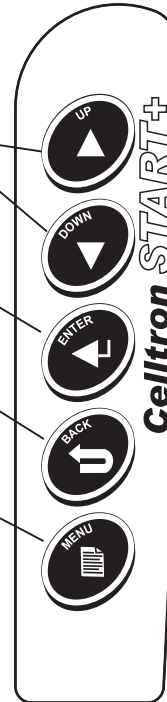

SELECTING A TEST MODE

The Celltron® START+™ Electrical System Analyzer performs two modes of testing: In-Vehicle and Out-Of-Vehicle.

IN-VEHICLE

The In-Vehicle mode performs testing on the battery pack, the individual batteries, the starting system and the charging system when the batteries are electrically connected and inside the vehicle.

OUT-OF-VEHICLE

The Out-Of-Vehicle mode prompts you through the testing of individual batteries that are either out of the vehicle or electrically disconnected from the the vehicle.

SELECTING A TEST OPTION

If you select the In-Vehicle test, the Celltron START+ offers the following options:

FULL SYSTEM prompts you through testing the battery pack, the individual batteries, the starting system and the charging system.

BATTERY PACK tests the condition of the battery pack and provides the option to test batteries individually.

STARTING SYSTEM performs a test on the starting system.

CHARGING SYSTEM performs a test on the charging system.

ENTERING BATTERY INFORMATION

BATTERY GROUP TYPE

The battery group type indicates the BCI (Battery Council International) battery size that best fits the physical dimensions of the vehicle. Select GROUP 31 or ALL OTHERS.

BATTERY VOLTAGE

There are certain battery pack configurations that use 6-volt batteries. When appropriate, the Analyzer will prompt you to choose the battery type. Select 12 VOLTS or 6 VOLTS.

NUMBER OF BATTERIES

When performing an In-Vehicle test, the Celltron START+ will prompt you to enter the number of batteries. Select from 1 to 4 batteries.

BATTERY RATING SYSTEM

The analyzer tests each battery according to the rating you choose. You will be prompted to choose the battery's rating system before scrolling to the actual rating. The available rating systems are:

- **CCA—Cold Cranking Amps.** The most common rating for cranking batteries at 0 °F (-18 °C).

- **CA—Cranking Amps.** Used in southern climates, where some batteries are rated at 32° F.
- **MCA—Marine Cranking Amps.** For testing marine batteries rated at 32° F.
- **JIS—Japanese Industrial Standard.** Shown on a battery as a combination of numbers and letters. For example, 8D26.

BATTERY RATING

Once the battery rating system has been selected, scroll to the rating specified on the battery (for example, 625 CCA). Press **ENTER**.

(See “Additional Features” for test code and other test parameters and “Individual Battery Test Results.”)

TESTING THE BATTERY PACK

The Celltron START+ can measure battery packs up to 3500 CCA. It is designed to give you a quick approximation of the pack’s state of health and its capability to deliver current. The Pack Test can only test the pack as a whole. A decision is not made on any one individual battery within the pack unless the pack is separated and the batteries are tested individually. Several factors can skew test results, such as pack configuration, cable types, cable age, steel bolts, and corrosion. To get a true determination of the battery pack, the batteries must be tested individually by connecting to either the lead pads or by using the lead post adapters.

IMPORTANT:

- The analyzer will compensate for cable resistance and steel bolt connections. Since pack configuration, cable age and corrosion are unpredictable, however, the Pack Test CCA result will always be less than that of the true pack CCA.
- Pack testing should always be performed at the terminals leading off to the rest of the vehicle.
- Using the Battery Pack Test on battery packs that have load-shedding technology, an isolated battery for accessories, or multiple cables going to the electrical system, can give misleading results.

BATTERY PACK TEST RESULTS

The analyzer will display the open circuit voltage, the cranking amps (units are based on the rating system you selected), and a decision in the following format:

12.62 V 1685 CCA
GOOD BAT.PACK

- **GOOD BAT.PACK**—The battery pack is in good shape when compared with its rating while being compensated for cable and connector resistance.
- **CHECK BAT.PACK**—After compensating for cable and connector resistance, the battery pack is in poor shape when compared with its rating. Check the connections and test the batteries separately.

TESTING INDIVIDUAL BATTERIES

At the end of the Pack Test, the analyzer will give you the option to test the batteries separately. If you choose YES, the analyzer will prompt you through the steps of disconnecting, testing each battery, and reconnecting the battery pack. If you select NO, the analyzer will store the Battery Pack Test results. If you selected a Full System Test, the analyzer will proceed to the Starting System Test.

INDIVIDUAL BATTERY TEST RESULTS

The analyzer will display the open circuit voltage, cranking amps (units are based on the rating system selected by the user) and one of the following decisions:

- **GOOD BATTERY**—The battery is in good condition. Return to service.
- **GOOD-RECHARGE**—Fully charge the battery. Return to service.
- **CHARGE & RETEST**—Fully charge the battery, remove surface charge, and retest. Failure to fully charge the battery before retesting may cause false readings.

- **REPLACE BATTERY**—Although a battery evaluated as “replace” may still start the vehicle, it no longer measures up to its minimum standard and will fail soon.
- **BAD CELL-REPLACE**—Replace the battery and retest to perform a complete system analysis

IMPORTANT: A REPLACE BATTERY result may mean a poor connection exists between the vehicle’s cables and the battery. After disconnecting the vehicle’s cables from the battery, retest the battery using the Out-Of-Vehicle Test before replacing.

TEST CODE

While viewing the battery test results, you will be prompted to press the **ENTER** button to obtain the test code. While viewing the test code, you will be prompted to press the **ENTER** button to begin the starter system test if the in-vehicle test was selected.

TESTING THE STARTER SYSTEM

A Starting System Test can be performed by itself or within a Full System Test.

IMPORTANT: Make sure the battery or battery pack is in a good state of charge before you perform a valid Starting System Test. If the result of the Battery Pack Test was CHECK BAT.PACK, or the result of the individual battery tests were CHARGE & RETEST or REPLACE, then charge or replace the batteries before doing the Starting System Test. When testing older model diesel engines in cold weather, pre-heating and post-heating of the glow plugs may skew the test results. Warm up the engine for 5 minutes, and then retest the vehicle.

SELECTING A STARTER TYPE

While performing a Full System Test, the analyzer will prompt you to select a starter type. Choose one of the following options:

- **Air**—The vehicle has an air starter. This selection will bypass the starting (electrical) system test. You will be prompted to start the engine, and then press **ENTER** to continue. The analyzer will proceed to the Charging System Test.
- **Conventional**—The vehicle has a conventional electrical starter. You will be prompted to start the engine. During the engine crank or starting cycle, the analyzer analyzes the starter for proper operation. At the conclusion of the test, the Analyzer will display one of the following results:

STARTER SYSTEM TEST RESULTS

The analyzer will display the cranking voltage of the starter and one of the following decisions:

- **CRANKING VOLTAGE NORMAL**—The starting system is showing normal starter draw.
- **CRANKING VOLTAGE LOW**—The cranking voltage is below typical limits; troubleshoot the starter electrical system using the manufacturer's recommended procedure. If you are performing a Full System Test, press **ENTER** to proceed to the Charging System Test.

TESTING THE CHARGING SYSTEM

A Charging System Test can be performed by itself or within a Full System Test. With the vehicle running, you will be prompted to perform steps necessary for the analyzer to perform a charging system analysis.

IMPORTANT: When testing older model diesel engines in cold weather, pre-heating and post-heating of the glow plugs may skew the test results. Warm up the engine for 5 minutes and then retest the vehicle.

Check the belts to ensure that the alternator is rotating when the engine is running. If the belts are slipping or broken, replace the belts and retest. Check all connections to and from the alternator, especially the connection to the battery. If the connection is loose or heavily corroded, clean or replace the cable and retest.

1. **The Celltron START+ displays real-time alternator output voltage:** Press **ENTER** to begin the Charging System Test.
2. **Testing at rev:** The analyzer will prompt you to rev the engine for 5 seconds. When the analyzer has detected the rev, it will collect data and show that it detected the rev. If the analyzer does not detect a rev, it will prompt you to press **ENTER** to continue after revving.

IMPORTANT: Vehicles may idle at a high rpm after starting. The analyzer may detect a rev without any action being taken. If this occurs, continue the test process. The final test results will not be affected.

3. **Testing at idle:** The analyzer will analyze the charging system output at idle for comparison to other readings.
4. **Diode ripple test:** The analyzer will look for the amount of ripple from the charging system to the battery. Excessive ripple usually means one or more diodes have failed in the alternator or there is stator damage.
5. **Testing with accessory loads:** After the Diode Ripple test, the Analyzer will go through the following prompts:
 - Turn on accessory loads (headlights, blower motor, defogger, etc.) of at least 40 amps.
 - Test at idle with loads on.
 - Rev the engine for another 5 seconds with loads on.

IMPORTANT: When asked to turn on the accessory loads, turn on the blower to high (heat), high-beam headlights and rear defogger. DO NOT use cyclical loads, such as air conditioning or windshield wipers.

6. **Analyzing data:** The analyzer will analyze all readings and provide the results of the Charging System Test.

CHARGING SYSTEM TEST RESULTS

The Analyzer will display several screens including charging system decision, charging system problem detail, load voltage measurements, and alternator ripple evaluation.

Charging System Decision

- **CHARGING SYSTEM NORMAL**—The charging system is operating within a normal voltage range.
- **CHARGING SYSTEM PROBLEM**—A problem was detected in the charging system. The charging system problem details are listed below.

Charging System Problem

- **NO CHARGING VOLTAGE**—The alternator is not providing charging current to the battery (pack).
- **LOW CHARGING VOLTAGE**—The alternator is not providing sufficient current for the system's electrical loads nor for charging the battery (pack).
- **HIGH CHARGING VOLTAGE**—The voltage output from the alternator to the battery (pack) exceeds the normal limits of a functioning regulator and could overcharge the battery (pack) and decrease its life.

Load Voltage Measurements

- **LOAD OFF**—Displays the measured voltage taken at idle with no accessories on.
- **LOAD ON**—Displays the measured voltage taken at idle with accessories switched on.

Alternator Ripple Evaluation

- **DIODE RIPPLE NORMAL**—The alternator's rectifier is functioning within its normal operating range.
- **EXCESS RIPPLE DETECTED**—One or more diodes of the alternator's rectifier may be defective.
- **DIODE RIPPLE NOT DETECTED**—The analyzer is not able to detect diode ripple through the battery cables or the alternator is not spinning.

MENU OPTIONS

To access one of the menu options below, press and hold the **MENU** button. In the Option Menu use the **ARROW** buttons to scroll to the desired option and press **ENTER** to select it.

IMPORTANT: The last test results will be lost when you start a new test.

VIEW RESULTS

Scroll to **VIEW RESULTS**, and press **ENTER**. Use the **ENTER** and **BACK** to scroll through the last test result, which will include the test code.

PRINT RESULTS

The analyzer also has the ability to print the last test result using the IR output at the top of the analyzer and the IR receiver of the printer (below the **MODE** button).

IMPORTANT: If you will be using the printer for the first time, charge the printer battery for 16 hours before beginning your test session. Refer to the printer manual for more information.

With the printer on, align the IR transmitter on the top of the analyzer with printer's IR receiver (below the **MODE** button). Press the menu button and scroll to the PRINT RESULTS option by pressing the **ARROW** buttons. When you are ready to print, press **ENTER**.

HINTS:

- 1. If the IR transmitter and receiver are not aligned, all the data may not print. Press **MENU** to cancel the print job. Verify alignment between the analyzer and printer, then try to print the test results again.*
- 2. It takes about 30 seconds to print all test results, which are displayed simultaneously on the screen.*

VOLTMETER

The Analyzer can also function as a voltmeter. The operating range of the voltmeter is 0 to 30 volts.

IMPORTANT: If the analyzer is connected to a voltage source greater than 30 volts, the circuit board might be damaged.

To use the voltmeter function, press and hold the **MENU** button. Use the **ARROW** buttons to scroll to the VOLTMETER option and press **ENTER**.

Use the red and black clamps as probes. The analyzer does not detect negative voltage. If the analyzer is connected in reverse polarity, the analyzer will shut off.

To turn off the voltmeter function, disconnect from the voltage source and press the **MENU** button. Additionally, the analyzer will automatically shut off if 0 Vdc is detected for 20 seconds.

SET ADDRESS

This option allows you to enter a custom shop name and address used on the analyzer printout.

From the Option Menu, scroll to the SET ADDRESS selection and press **ENTER**. The analyzer will prompt you through each line of the name and address. Use the **ARROW** buttons to change characters. Use the **ENTER** and **BACK** buttons to move to the next or previous position.

PERFORM TEST

This option enables you to begin a new test without disconnecting from the battery and reentering test parameters.

ADDITIONAL FEATURES

SYSTEM SAVER

While the analyzer is powered only by its internal 9-volt battery (i.e., the clamps are not connected to a 12-volt battery or pack), the analyzer will power-off after 20 seconds (except while printing) if no keypad selections are made. This helps prolong the life of the internal battery.

If the analyzer is allowed to time-out during a test, the test sequence and data are saved. You can reactivate the analyzer by pressing the **MENU** button or by reconnecting the battery clamps.

The analyzer will prompt you to continue the previous test. If you select **NO**, the analyzer will return to the Option Menu or to the Choose Test Menu (if the clamps were reconnected to the battery). If the test is to be continued, reconnect the battery clamps and select **YES**, then press **ENTER**.

SURFACE CHARGE REMOVAL

If surface charge is detected while testing in the vehicle, the analyzer will prompt you to turn on loads to remove the surface charge. Follow the instructions on the display. When finished, press **ENTER**. The analyzer will automatically resume testing.

IMPORTANT: When asked to turn on the accessory loads, turn on the blower to high (heat), high-beam headlights and rear defogger. Do not use cyclical loads, such as air conditioning or windshield wipers.

TEMPERATURE COMPENSATION

If necessary, the analyzer will prompt you to choose if the battery temperature is above or below 32° F (0° C). Choose the appropriate selection by scrolling with the **ARROW** buttons, then press **ENTER**.

BEFORE AND AFTER CHARGE TESTS

If necessary, the analyzer will ask you if the battery has just been charged. Choose the appropriate selection by scrolling with the **ARROW** buttons, then press **ENTER**.

Note: When testing a battery installed in a vehicle that has recently been driven, use the Before Charge Test.

GLOW PLUG DETECTION

If necessary during the Charging System Test, the analyzer will ask you if the vehicle has glow plugs. Choose the appropriate selection by scrolling with the **ARROW** buttons, then press **ENTER**.

If you select NO, the test is concluded and the charging system results are displayed. Press **ENTER** to begin reviewing complete results, if a Full System Test was conducted.

If you select YES, the analyzer begins a 40-second countdown. The countdown allows post-heating of the glow plugs to finish so a proper charging system evaluation can be made. If post-heating finishes within 40 seconds, the Charging System Test continues. If post-heating does not finish, the test is concluded and the charging system results are displayed. If you conducted a full system test, press **ENTER** to review the test results.

TROUBLESHOOTING

DISPLAY PROBLEMS

If the display does not turn on:

- Check the connection to the vehicle battery or pack.
- The vehicle battery may be too low to power the analyzer (below 1 volt). Fully charge the battery and retest.
- The analyzer's 9-volt battery may need to be replaced. Follow the directions in "Replacing the Analyzer Battery" and replace the 9-volt battery (alkaline recommended).
- If the analyzer detects computer or ignition noise, a SYSTEM NOISE message will appear. Verify that all vehicle accessory loads are off and the ignition switch is in the OFF position. The analyzer will automatically retest when the system noise is no longer detected. If the SYSTEM NOISE message continues after several retest attempts, disconnect the battery cables and retest.
- Batteries that are very weak or that have just been charged may have sufficient electrical activity to alter test results. Should this occur, an UNSTABLE BATTERY message will appear. The analyzer will automatically retest when the battery has stabilized. Fully charged batteries should stabilize quickly. Weak batteries should be fully charged, then retested.
- If troubleshooting does not solve the problem, call 800-776-1995 to obtain service. See "Patents, Limited Warranty, Service" for more information.
- If the analyzer does not power on when you press and hold the **MENU** button, replace the 9-volt battery.

PRINTING PROBLEMS

Status LED

When a printer fault occurs, the **STATUS LED** will flash. You can identify the fault by the number of sequential flashes:

Sequence	Condition	Solution
* * *	Paper out	Fit new paper
** ** **	Thermal head too hot	Allow head to cool
*** *** ***	Battery low	Recharge printer battery for 16 hours

Solutions

- If the IR transmitter and receiver are not aligned, all the data may not print. The infrared ports on the top of the analyzer and on the front of the printer (below the **MODE** button) should be pointed directly at each other. The maximum distance for reliable transmission between the ports is 18 inches (45 cm).
- If the analyzer displays PRINTING RESULTS, but the test results are not printing, press **MENU** to cancel. Turn off the printer and charge the printer battery for at least 15 minutes before attempting to print again. To realign, press **MENU** to cancel the print job. Verify alignment between the analyzer and printer; then try to print the test results again.
- Make sure the printer is on. The printer shuts off after 2 minutes of inactivity to conserve the battery. To turn the printer on, briefly press the **MODE** button. The green **STATUS** light should turn on. Make sure you are using the Midtronics printer provided with the analyzer. Other printers may not be compatible.
- Direct sunlight interferes with infrared data transmission/receiving. If the printer is not receiving data, remove the printer and analyzer from direct sunlight. If the printed characters are not clear or are partially missing, recharge the battery and reprint.

- If you are unable to print after ensuring the analyzer is functioning, the printer is on, the battery is good, and the IR transmitter and receiver are aligned, check the printer manual for further instructions or call Midtronics at 800-776-1995 for assistance.

REPLACING THE ANALYZER BATTERY

The Celltron START+ uses a 9-volt battery (alkaline recommended) to allow testing of batteries down to 1 volt as well as supply power while the Option menu is active. When the internal battery requires replacing, the analyzer will display LOW INTERNAL BATTERY, REPLACE. You should change the battery as soon after the message is displayed as possible.

Note: The analyzer will retain setup information while you change the 9-volt battery.

IMPORTANT: The analyzer can test down to 5.5 volts when the internal 9-volt battery is not functioning.

1. Remove the cover to the battery door using a small screwdriver.
2. Insert a 9-volt battery as shown below, making sure the positive and negative terminals are positioned correctly.
3. Put the back cover and tighten the screw.

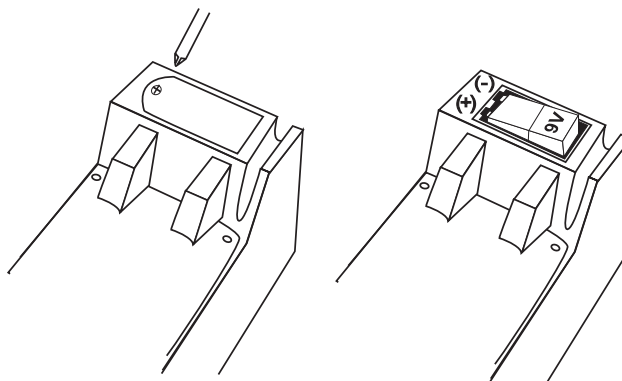

NOTES

NOTES

PATENTS

Made in the U.S.A. by Midtronics, Inc. and is protected by one or more of the following U.S. Patents: 6,469,511; 6,456,045; 6,445,158; 6,441,585; 6,392,414; 6,323,650; 6,316,914; 6,310,481; 6,304,087; 6,249,124; 6,225,808; 6,163,156; 6,091,245; 6,051,976; 5,831,435; 5,821,756; 5,757,192; 5,592,093; 5,585,728; 5,572,136; 4,912,416; 4,881,038; 4,825,170; 4,816,768; 4,322,685. Canadian Patents: 1,295,680; 1,280,164. United Kingdom Patents: 0,672,248; 0,417,173. German Patents: 693 25 388.6; 689 23 281.0-08; 93 21 638.6. European patents: C382.13-0040 WO; C382.13-0033 EP; C382.13-0018 EP. And other U.S. and Foreign patents issued and pending. This product may utilize technology exclusively licensed to Midtronics, Inc. by Johnson Controls, Inc. and /or Motorola, Inc.

LIMITED WARRANTY

This Midtronics Celltron START+ Electrical System Analyzer is warranted to be free of defects in materials and workmanship for a period of 1 year from date of receipt. Midtronics will, at our option, repair the unit or replace the unit with a remanufactured analyzer. This limited warranty applies only to the Midtronics Celltron START+ Electrical System Analyzer and does not cover any other equipment, static damage, water damage, overvoltage, dropping the unit or damage resulting from extraneous causes including owner misuse. Midtronics is not liable for any incidental or consequential damages for breach of this warranty. The warranty is void if owner attempts to disassemble the unit, or to modify the cable assembly.

SERVICE

To obtain service, purchaser should contact Midtronics for a Return Authorization number, and return the unit to Midtronics freight prepaid, Attention: RA# _____. Midtronics will service the analyzer and reship the next scheduled business day following receipt, using the same type carrier and service as received. If Midtronics determines that the failure was caused by misuse, alteration, accident, or abnormal condition of operation or handling, purchaser will be billed for the repaired product and it will be returned freight prepaid with freight charges added to the invoice. Battery analyzers beyond the warranty period are subject to the repair charges in effect at that time. Optional remanufacturing service is available to return the analyzer to like-new condition. Out-of-warranty repairs will carry a 3-month warranty. Remanufactured units purchased from Midtronics are covered by a 6-month warranty.

Midtronics, Inc.
7000 Monroe Street
Willowbrook, IL 60527
U.S.A.
Phone: 630.323.2800
Fax: 630.323.2844
ISO 9001 Certified

Midtronics Canada, Inc.
54 Ferris Drive
P.O. Box 746
North Bay, Ontario
P1B 8J8 Canada
Phone: 705.476.9228
Fax: 705.476.9255

Midtronics b.v.
Lage Dijk-Noord 6
3401 VA IJsselstein
The Netherlands
Phone: +31 306 868 150
Fax: +31 306 868 158
ISO 9001:2000 Certified

www.midtronics.com
Toll free in North America: 800.776.1995



