

Model: DCE DC Energy Monitor

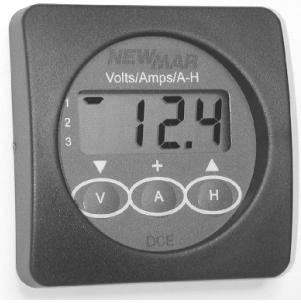

INSTALLATION/OPERATION MANUAL

Introduction

The DCE provides accurate low cost instrumentation for 3 banks of batteries between 9.5 and 33 Volts. The unit displays voltage for three banks and amps or amp-hours for your house bank. It tracks all current entering and leaving the house bank and applies Peukert's and efficiency factors. You can set Low and High voltage alarms and Low Amp-Hours Remaining alarms on the house bank. When activated, the built-in 85 dB alarm will sound and the display will flash. The DCE outputs NMEA 0183 serial data or the data line can be programmed as an external alarm output or as a charger on-off control. Five levels of backlighting can be selected and all set-up, calibration constants and alarm values are saved to non-volatile memory. The DCE comes complete with a precision 500 amp shunt and is designed to work with 50-500 amp 50mV shunts. (Unit must be recalibrated if other than 500 amp shunt is used.)

Installation

Before starting the installation, please read this entire section first. The instrument may be installed in a bulkhead or in NEWMAR's Single or Dual Universal Meter Panel Blanks (contact factory). Remove the rear bracket, attach wiring as explained in the following section, then reassemble and install as shown in the diagram below. Finger tighten the nuts that secure the bracket - do not use tools. (You may use Lock-Tite to keep the nuts from vibrating loose.) Be sure to slide the bulkhead gasket over the instrument body before you install the instrument.

Drill a 2-1/8" (55mm) mounting hole (or use NEWMAR's Single or Dual Universal Meter Panel Blanks) as shown in FIGURE 1.

FIGURE 1

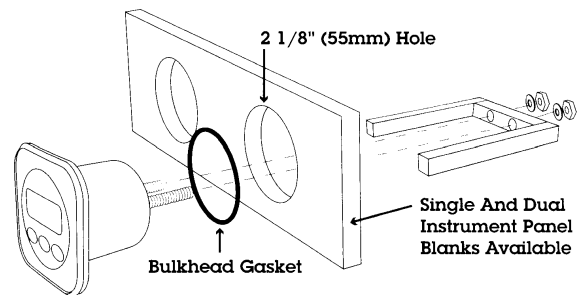

Bring the shunt wires, ground, and power lines out of the mounting hole and through the large opening in the DCE mounting bracket. Use a small flat-tip screwdriver to make the connections to the screw terminal on the instrument case back as shown in FIGURE 2 and FIGURE 3.

FIGURE 2

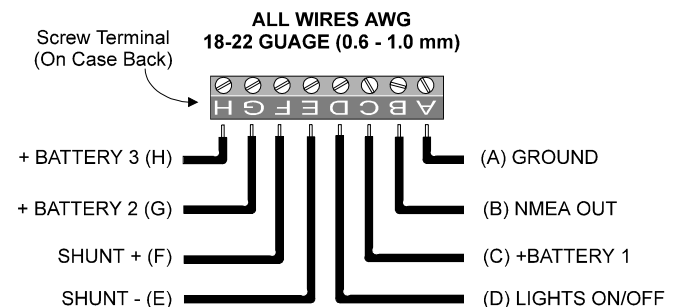

(FIGURE 3 ON REVERSE)

M-DCE
APR 2004



ELECTRONIC POWER PRODUCTS
COMMUNICATION • NAVIGATION

www.newmarpower.com

P.O. Box 1306
Newport Beach,
California 92663

Phone: 714-751-0488
Fax: 714-957-1621
E-Mail: sales@newmarpower.com

FIGURE 3

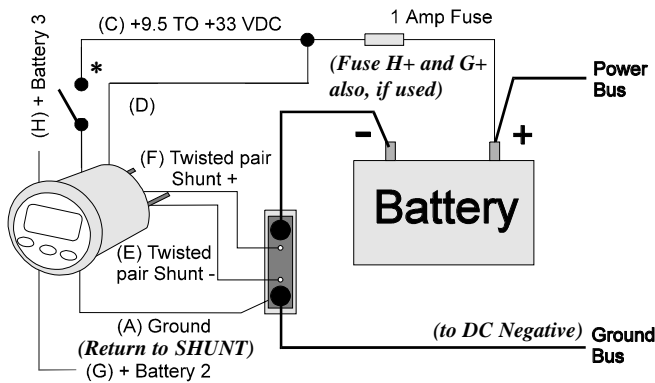

* Note: Optional programming On-Off switch may be installed in line with terminal C. Locating this switch near the DCE will simplify the programming of certain functions such as the battery bank capacity, charge efficiency and Peukert's Exponent. While the factory set (default) values of the latter two functions will work in most situations, the default value for battery bank capacity (factory set at 500A-H) will vary from installation to installation.

Carefully check all your wiring against that shown in FIGURES 2 and 3. If everything is wired correctly you can mount the DCE in the instrument hole. Be sure the bulkhead gasket is in place and use only finger tension to tighten the bracket hold-down nuts. Do not overtighten the bracket or you may damage the case - do not use tools to tighten the nuts.

Note: Because wire lengths and sizes will vary with each installation, the auto zero procedure that follows should be performed to initialize the unit.

Auto Zero Procedure

To make the ammeter read zero when no current is flowing, press and hold the \oplus key for 10 seconds while viewing Amps. The DCE will display "AUTO", automatically zero the reading and save the auto-zero information into memory. If the reading does not stop at zero, repeat the above procedure until it does.

Calibrating/Zeroing the Instrument

The DCE is factory calibrated and under most circumstances should not require re-calibration after being installed. If however, you suspect, then confirm incorrect

voltage and/or amperage readings, the unit may be re-calibrated as follows:

To re-calibrate the voltmeter, press and hold the **V** key while applying power to the instrument. Use the \triangle and ∇ keys to make the displayed value read correctly. Press the \oplus key for 1/2 second to save the calibration data to memory.

To re-calibrate the Ammeter, press and hold the **A** key while applying power to the instrument. Use the \triangle and ∇ keys to make the displayed value read correctly. Press the \oplus key for 1/2 second to save the calibration data to memory.

Key Functions

The **V**, **A**, and **H** keys are used to select what to display, backlights, calibrate volts/amps, turn alarms on/off, set alarms and set/change constants. New information is automatically saved to memory.

Turning Alarms ON/OFF

Press the \triangle key 1/2 second to turn alarms ON. In Voltage mode, the Battery 1 icon will blink. Press the ∇ key 1/2 second to turn the alarms OFF.

Backlight Intensity

Press \oplus the key 1/2 second to adjust the backlight level for night-time viewing. Each time you press the \oplus key 1/2 second, the level will get brighter 1, 2, 3, 4, OFF, 1, 2...etc. Screw terminal pin (D) must be connected to battery hot (+) for the backlights to work.

Display Volts/Amps/A-H/ A-H % Remaining

Quick press the **V**, **A** or **H** keys to select Battery Voltage, Amps or Amp-Hours display. Pressing the



V key repeatedly will step the display through Battery 1, 2, 3, 1, etc. To display the Capacity Remaining (Amp-Hours % Remaining), press the **A** and

H keys simultaneously.

Setting High Volts Alarm

While viewing Battery #1 volts, press and hold the Δ key for ten (10) seconds. You will hear a beep and the High Volts alarm value will be displayed. Use the Δ and ∇ keys to set the desired alarm value. Press the \oplus key for 1/2 second to save the High Volts Alarm value to memory.

Setting Low Volts Alarm

While viewing Battery #1 volts, press the ∇ key for ten (10) seconds. You will hear a beep and the Low Volts alarm value will be displayed. Use the Δ and ∇ keys to set the desired alarm value. Press the \oplus key for 1/2 second to save the new alarm value.

Setting Low Amp-Hours Alarm

While viewing Amp-Hours, press and hold the ∇ key for ten (10) seconds. You will hear a beep and the Low Amp-Hours alarm value will be displayed. Use the Δ and ∇ keys to change it. Press the \oplus key for 1/2 second to save the new value.

Changing Battery Capacity

Press and hold the Δ key while applying power to the DCE. The Battery Capacity (in Amp-Hours) will be displayed. Use the Δ and ∇ keys to change it. Press the \oplus key for 1/2 second to save it.

Changing Charge Efficiency

The Default Charge Efficiency is 80% (meaning you get back 80% of what you put into the battery). To change it, press and hold both the ∇ and Δ keys and apply power to

the DCE. Charge Efficiency % is displayed. Use the Δ and ∇ keys to change it. Press the \oplus key for 1/2 second to save the new value.

Changing Peukert's Exponent

Peukert's Exponent relates how efficiently you can draw current from a battery. Because of inefficiencies, the faster you drain the battery, the smaller it appears to be. The default Peukert's Exponent is 1.25 (shown as 125), which is typical for many batteries. To change it, press and hold the \oplus and Δ keys while applying power to the instrument.

Peukert's exponent will be displayed. Use the Δ and ∇ keys to set the desired value. Press the \oplus key for 1/2 second to save the new value. If your battery seems to discharge faster than what the DCE is telling you, try increasing Peukert's Exponent slightly. Lower the exponent if the reverse is true. The correct setting will depend upon how your battery was manufactured and it's age, etc.

NMEA 0183 Sentences

Volts: \$IIXDR,U,xx.x,V,VAH35,*CS
Amps: \$IIXDR,I,xxxx,A,VAH35,*CS
A-H Remaining: \$IIXDR,G,xxxx,VAH35,*CS
*CS = Check Sum

Selecting NMEA 0183, External Alarm or Charger Control Output

Screw terminal pin (B) can be programmed as an NMEA 0183 Data Output, External Alarm Output, or as a Charger On-Off Control. The factory default is NMEA 0183 serial data output.

To toggle Screw Terminal Pin (B) between NMEA 0183, External Alarm Output and Charger Control, press and hold down both the Δ and ∇ keys for 10 seconds (until you hear a long beep). The display will toggle between showing "dAtA" (Data), "E-AL" (External Alarm) or "-CC-" (Charger Control) to show you which mode is selected. The new output mode is automatically saved to memory.

A 5V signal (10 mA Max.) is output on screw terminal (B) whenever an alarm condition exists and the alarms are enabled or whenever a charger is to be turned on automatically.



Setting Charge Control On-Off Limits

If the Charger Control function is selected for screw terminal (B), the DCE can be programmed to automatically turn a charger on and off, depending on the amp-hours remaining. The factory default is to turn the charger on when Amp-Hours Remaining drops to 50% of battery capacity and switch off when it returns to 90% of capacity. Screw terminal (B) outputs a +5V signal to activate the charger.

To set the upper charge control output limit (charger "off" point) in percent, press both the \oplus and ∇ keys to display amp-hours remaining in percent. Then hold the ∇ key down for 10 seconds (until you hear a long beep). The upper charge limit will be displayed in percent. Use the \triangle and ∇ keys to set the desired value. Use the \oplus key to save the new value to memory.

To set the lower charge control limit (charger "on" point) in percent, press both the \oplus and \triangle keys to display amp-hours remaining in percent. Then hold the \triangle key down for 10 seconds (until you hear a long beep). The lower charge limit will be displayed in percent. Use the \triangle and ∇ keys to set the desired value. Use the \oplus key to save the new value to memory.

Resetting Amp-Hours Remaining

While viewing Amp-Hours Remaining, press and hold the \triangle key for 10 seconds (until you hear a long beep). The Amp-Hours Remaining will be reset to the full amp-hour capacity of the battery.

Adjusting Amp-Hour Drift

If the battery system remains unused for several weeks, the amp-hour tracking function of the DCE will start to lose accuracy. This is because small calibration and measurement errors can accumulate, causing the displayed amp-hours to "drift" so that it no longer reflects true amp-hours remaining. To minimize this long term drift, you can program an amp-hours drift compensation value between 0 and 100, which will increase the accuracy. The nominal drift value is 55. To change this value, press and hold both the \oplus and \triangle keys when applying power to the DCE. Use the \triangle and ∇ keys to set the desired value. Press the \oplus key for 1/2 second to save the new value.

If the displayed amp-hours is drifting down faster than actual amp-hours, increase the drift compensation value slightly. If it is drifting upward faster, then decrease the value slightly.

Notes and Warnings

- When setting functions that require you to hold down a key while applying power - turn OFF the power, then hold the key(s) down during and for at least 3 seconds AFTER the power has been applied.
- A display of " - - - - " means the unit thinks the amp reading is greater than -500 amps.
- It is important to run the ground wire from pin A all the way back to the shunt negative.

NMEA 0183 Sentences

Volts: \$IIXDR,U,xx.x,V,VAH35,*CS

Amps: \$IIXDR,I,xxxx,A,VAH35,*CS

A-H Remaining: \$IIXDR,G,xxxx, ,VAH35,*CS

*CS = Check Sum

Specifications

Power supply: 9.5 to 33.0 VDC, .018 amps nominal

Operating temperature: 32 to 122 F (0 to 50 C)

Size: 2.5" dia X 4.1" deep (61mm x 104 mm).

Accuracy: Better than +/- 0.1 VDC for volts and 1% +/-1 Amp for amps, front panel adjustable.

Ranges:

Volts 1,2 & 3	-	9.5 to 33.0 VDC
Amps	-	-500 to +500 Amps*
Amp-Hours	-	100 to 3000 A/H*
Capacity Remaining	-	0 to 100%*

Shunt: 500 Amp, 50mV*

**Applies to Bank 1 (house bank) only*

Alarms: High, Low Voltage & Low Amp-Hours

Display: 4 digit LCD, 5 levels of backlighting.

NMEA 0183: \$IIXDR,V; \$IIXDR,A; \$IIXDR,G

